

# YC6K600-D30

**Prime power:401 kW @ 1500 r/min**

**Standby power:441kW @ 1500 r/min**

Emission regulations to be observed:

GB 20891-2014 Stage III

ECE R96 Stage IIIA

## Introduction

After more than 10 years of market test, YC6K series engines are widely applied in heavy buses, heavy trucks, engineering machineries, ships and generator units. After being updated to the electronically-control high pressure common rail configuration, the engine meets the non-road stage III emission standards, and it has sufficient margin, stronger power, lower fuel consumption and better transient loading capacity.

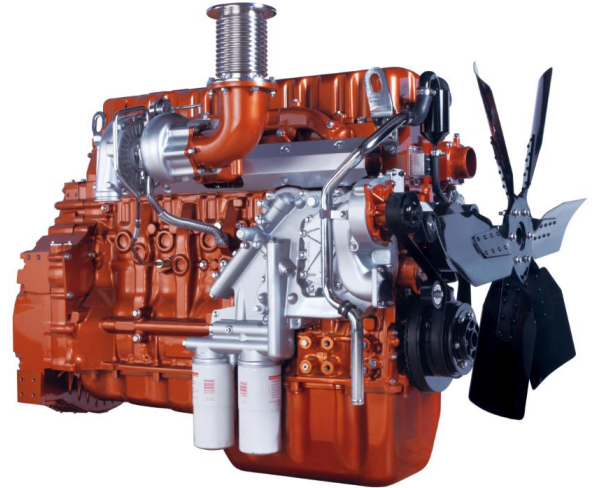

(Image shown may not reflect actual engine)

## Product Features

- ◆ Integral crankcase and integral cylinder head are adopted, which ensure good reliability. Wet cylinder liner is adopted, which ensures the wear resistant and easy maintenance.
- ◆ High-strength alloy crankshaft is adopted, which ensures good wear resistance, and long service life.
- ◆ The internal cooling oil passage technology is adopted for piston, which ensures high temperature resistance and good reliability.
- ◆ Advanced and mature electronically-control high pressure common rail fuel system and secondary injection technology are adopted, ensuring better dynamic performance and lower fuel consumption.
- ◆ G3 performance requirements for generator set are met.

## Product Service

- ◆ Service: Yuchai has built the largest service network in the industry with the minimum service radius, the most extensive “three guarantees” and the shortest response time. 49 global offices are set up, including 14 overseas offices in Europe, Africa and South America etc. Besides, 108 overseas service agents, more than 3,000 service stations and 5,000 sales networks of fittings are established, providing the users with satisfying and considerate services.
- ◆ 24h global service hotline: +86 95098.

Engine speed	Application	Standard generator unit output		Engine power			
				Total power		Net power	
r/min		kVA	kW	kW	Ps	kW	Ps
1500	Prime	450	360	401	545	381	518
	Standby	/	/	441	600	430	585

## Notes:

1. Prime Power: which corresponds to the basic power (PRP) described in ISO 8528. Implement the maintenance according to the Yuchai's requirement, maximum power of variable load continuous output unlimited time. The average output power shall not exceed 70% of the prime power in every 24 hours of operation.

Standby Power: In correspondence with the emergency standby power (ESP) stated in ISO 8528. Implement the maintenance according to the Yuchai's requirement, maximum power at a variable load in the event of a main power network failure up to a maximum of 200 hours per year. The average output power shall not exceed 70% of the standby power in every 24 hours of operation.

2. The engine power data stated in the table is the measured performance under the condition stated in ISO 8528-1 and ISO 3046.
3. The power output of the generator unit is calculated according to the efficiency of the AC generator. Thus, it is for reference only.
4. The kVA and kW values are converted as per standard power factor 0.8.
5. The information mentioned above is the latest one, however, the relevant information may be altered after publication.

Engine load	1800 r/min	
	g/ (kW·h)	L/h
Standby power	/	/
Prime power	195	84.1
75% prime power	194	62.7
50% prime power	192	41.4

Remarks: the diesel oil density is 0.835g/cm<sup>3</sup>.

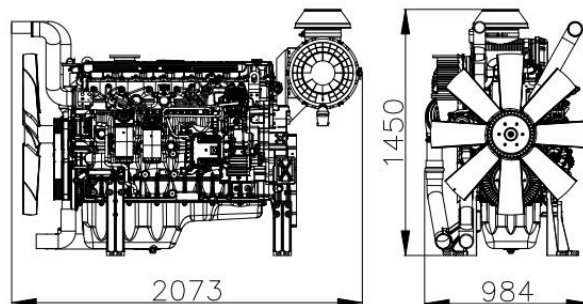

## Technical Data

Type	Vertical, in-line, water-cooled, four-stroke
Induction system	Turbocharged & Intercooled
Type of combustion chamber	Direct-injection reentrant $\omega$ combustion chamber
Cylinder quantity - Bore x Stroke	6-129×165mm
Number of valve per cylinder.	4
Displacement	12.94L
Compression ratio	17.5:1
Cylinder type	Wet-type cylinder sleeve
Working sequence	1-5-3-6-2-4
Fuel supply system	Electronically-control high pressure common rail
Lubrication mode	Combination of pressure and splashing
Starting mode	Electric
Engine oil capacity	32L (dry-type engine)
Engine oil and fuel consumption ratio	≤0.3%
Rotation	Anticlockwise (facing the power delivery end)
Minimum no-load speed.	(650±25)r/min
Speed-regulation grade	ISO 8528 G3
Noise <i>L<sub>p</sub></i>	≤102dB(A)
Total dry weight	
Engine	1300 kg
Radiator	

The final weight and sizes of the engine varies according to the specific arrangement.

## Engine Arrangement

- **Air intake system**
    - Air filter
  - **Cooling system**
    - Radiator (optional)
  - **Electrical device**
    - 24V electrical system
    - Inlet preheater (optional)
  - **Fuel system**
    - Electronically-control high pressure common rail system
    - Fuel Filter(two-stage diesel filter)
  - **Lubrication system**
    - Engine oil filter
  - **Flywheel and flywheel housing**
    - SAE14" flywheel
    - SAE 1# flywheel housing
  - **Documents**
    - Operation instruction
    - Installation guide
    - Parts catalog
- Fuel grade: Summer: 0# and 10# ordinary diesel oil of GB 252-2015 premium grade or first grade. Winter: 0#, -10#, -20#, and -35# ordinary diesel oil of GB 252-2015 premium grade or first grade.
- Oil brand: 15W-40 in summer; 10W-30 or other environmentally suitable diesel engine oils with the quality grade not lower than Grade CH-4 as provided in GB 11122-2006 in winter.