

YC6B180L-D20

Prime power: 120 kW @ 1500 r/min

Standby power: 132 kW @ 1500 r/min

For clients in the places where emission regulations have not been implemented yet.

Introduction

YC6B series engine developed by Yuchai, is a classic power product with high brand popularity and high market recognition. YC6B180L-D20 engine used for generator unit is characterized by reliability and durability, energy-saving and environment-friendly, compact structure, strong transient loading capability, good maintainability and high cost performance.

Product Features

- ◆ The main structures, such as engine body, are time-tested, which ensures the high reliability of the whole engine.
- ◆ Full-flow oil cooler is adopted; thus heat dissipation efficiency is increased by 30% and oil temperature is effectively reduced; and the oil can lubricate the parts under reasonable temperature to reduce the friction loss.
- ◆ The internal cooling oil passage technology is adopted for piston, which effectively reduces piston temperature and ensures the long service life.

Version No.: 2018V01 Implemented on: 2018-03-01

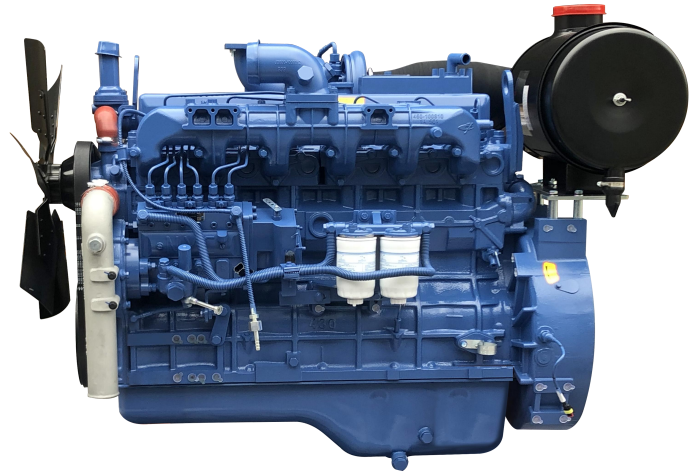

(Image shown may not reflect actual engine)

Product Service

- ◆ Service: Yuchai has built the largest service network in the industry with the minimum service radius, the most extensive “three guarantees” and the shortest response time. 49 global offices are set up, including 14 overseas offices in Europe, Africa and South America etc. Besides, 108 overseas service agents, more than 3,000 service stations and 5,000 sales networks of fittings are established, providing the users with satisfying and considerate services.
- ◆ 24h global service hotline: +86 95098.

Engine speed	Application	Standard generator unit output		Engine power			
				Total power		Net power	
r/min		kVA	kW	kW	Ps	kW	Ps
1500	Prime	125	100	120	163	116	158
	Standby	137.5	110	132	180	128	174

Notes:

1. Prime Power: which corresponds to the basic power (PRP) described in ISO 8528. Implement the maintenance according to the Yuchai's requirement, maximum power of variable load continuous output unlimited time. The average output power shall not exceed 70% of the prime power in every 24 hours of operation.
Standby Power: In correspondence with the emergency standby power (ESP) stated in ISO 8528. Implement the maintenance according to the Yuchai's requirement, maximum power at a variable load in the event of a main power network failure up to a maximum of 200 hours per year. The average output power shall not exceed 70% of the standby power in every 24 hours of operation.
2. The engine power data stated in the table is the measured performance under the condition stated in ISO 8528-1 and ISO 3046.
3. The power output of the generator unit is calculated according to the efficiency of the AC generator. Thus, it is for reference only.
4. The kVA and kW values are converted as per standard power factor 0.8.
5. The information mentioned above is the latest one, however, the relevant information may be altered after publication.

Engine load	1500 r/min	
	g/ (kW·h)	L/h
Standby power	201.3	31.8
Prime power	198.4	28.5
75% prime power	203.1	21.9
50% prime power	211.7	15.2

Remarks: the diesel oil density is 0.835 kg/L.

Technical Data

Type	Vertical, in-line, water-cooled, four-stroke
Induction system	Turbocharged & Intercooled
Type of combustion chamber	Direct-injection reentrant ω combustion chamber
Cylinder quantity - Bore x stroke.	6-108×125mm
Number of valve per cylinder.	2
Displacement	6.871L
Compression ratio	17.5:1
Cylinder type	Wet-type cylinder sleeve
Working sequence	1-5-3-6-2-4
Fuel supply system	Mechanical pump + electronic governor
Lubrication mode	Combination of pressure and splashing
Starting mode	Electronic
Engine oil capacity	17L (dry-type engine)
Engine oil and fuel consumption ratio	≤0.1%
Rotation	Anticlockwise (facing the power delivery end)
Minimum no-load speed.	(650~700)r/min
Speed-regulation grade	ISO 8528 G3
Noise <i>L_p</i>	≤95.6dB(A)
Total dry weight	
Engine	700kg
Radiator	75kg

The final weight and sizes of the engine varies according to the specific arrangement.

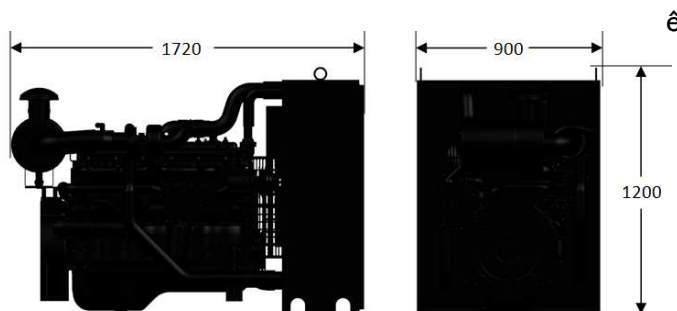

Engine Arrangement

➤ Air Intake System

Air filter

➤ Cooling system

Radiator (optional)

➤ Electrical device

24V/12V electrical system

➤ Fuel system

Fuel Filter

➤ Lubrication system

Engine oil filter

➤ Flywheel and flywheel housing

SAE 11.5" flywheel

SAE 2# flywheel housing

➤ Documents

Operation Instruction

Installation Guide

Parts catalog

Fuel grade: Summer: 0# and 10# ordinary diesel oil of GB 252-2015 premium grade or first grade. Winter: 0#, -10#, -20#, and -35# ordinary diesel oil of GB 252-2015 premium grade or first grade.

Oil brand: 15W-40 in summer; 10W-30 or other environmentally suitable diesel engine oils with the quality grade not lower than Grade CH-4 as provided in GB 11122-2006 in winter.