

YC16VC4000-D31

Prime power: 2673 kW @ 1500 r/min

Standby power: 2940 kW @ 1500 r/min

Emission regulations to be observed:

GB 20891-2014 Stage III

Version No.: 2021V01 Implemented on: 2021-9-10

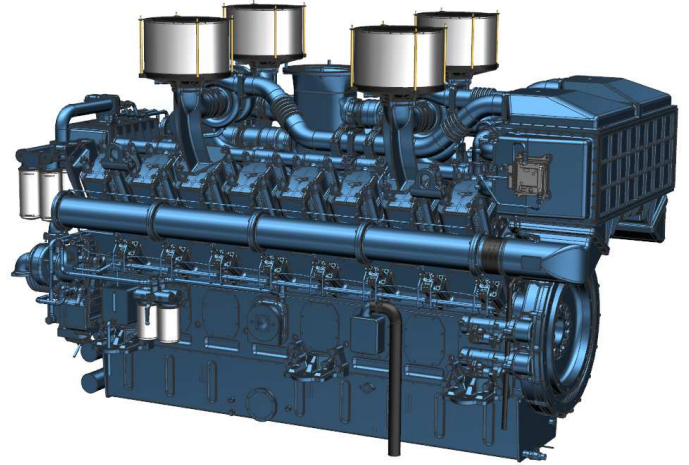

Introduction

YC16VC series engine developed independently by Yuchai is a classic product. It is characterized by energy-saving and environment-friendly, excellent performance, compact structure, and reliability and durability; the indexes, such as pollutant emission, dynamic performance, economy, and reliability, reach the international advanced level.

Product Features

- ◆ Electronic unit pump, four-valve structure, high-efficiency turbocharged & secondary intercooling structure, and Yuchai combustor technologies are adopted for realizing low fuel consumption, less emission, outstanding speed governing performance, and fast and high-quality loading.
- ◆ High-strength material, reinforced grid structure with cambered surface, and 4-bolt main bearing structure are adopted for the engine body; thus the engine body is characterized by high stiffness, slight vibration, and lower noise.
- ◆ The crankshaft is made of high-quality alloy steel by using all fiber extrusion forging process, and the journal and circular bead are subject to quenching heat treatment for improving wear resistance and prolonging service life.

- ◆ The world-class equipment and technologies are used for production; thus, the quality of such model is stable and reliable.
- ◆ The structure of one head for one cylinder is adopted; maintenance window is set at the side of the engine body, which ensures easy maintenance.
- ◆ G3 performance requirements for generator set are met.

Product Service

- ◆ Service: Yuchai has built the largest service network in the industry with the minimum service radius, the most extensive “three guarantees” and the shortest response time. 49 global offices are set up, including 14 overseas offices in Europe, Africa and South America etc. Besides, 108 overseas service agents, more than 3,000 service stations and 5,000 sales networks of fittings are established, providing the users with satisfying and considerate services.
- ◆ 24h global service hotline: +86 95098.

Engine speed	Application	Standard generator unit output		Engine power			
				Total power		Net power	
r/min		kVA	kW	kW	Ps	kW	Ps
1500	Prime	3000	2400	2673	3637	2551	3471
	Standby	3250	2600	2940	4000	2818	3834

Notes:

1. Prime Power: which corresponds to the basic power (PRP) described in ISO 8528. Implement the maintenance according to the Yuchai's requirement, maximum power of variable load continuous output unlimited time. The average output power shall not exceed 70% of the prime power in every 24 hours of operation.

Standby Power: In correspondence with the emergency standby power (ESP) stated in ISO 8528. Implement the maintenance according to the Yuchai's requirement, maximum power at a variable load in the event of a main power network failure up to a maximum of 200 hours per year. The average output power shall not exceed 70% of the standby power in every 24 hours of operation.

2. The engine power data stated in the table is the measured performance under the condition stated in ISO 8528-1 and ISO 3046.
3. The power output of the generator unit is calculated according to the efficiency of the AC generator. Thus, it is for reference only.
4. The kVA and kW values are converted as per standard power factor 0.8.
5. The information mentioned above is the latest one, however, the relevant information may be altered after publication.

Engine load	1500 r/min	
	g/ (kW·h)	L/h
Standby power	217.2	764.8
Prime power	210.5	673.9
75% prime power	205.6	493.6
50% prime power	217.3	347.8

Remarks: the diesel oil density is 0.835 kg/L.

Technical Data

TypeVertical, V-type, water-cooled, four-stroke
 Aspiration..... Turbocharged & Intercooled
 Type of combustion chamberDirect injection ω type
 Number of cylinders - bore × stroke... ..16-200×210mm
 Number of per cylinder valves4
 Displacement105.56L
 Compression ratio13.5:1
 Cylinder type... ..Wet cylinder liner
 Firing order.....**A1-B1-A6-B6-A2-B2-A5-B5-A8-B8-A3-B3-A7-B7-A4-B4** Viewed from the back end: numbered starting from 1, with A for left side, and B for right side
 Fuel supply systemElectronic unit pump
 Lubrication method... ..Pressure & splash
 Starting mode.Electronic
 Oil capacity... ..430L
 Oil-fuel ratio... ..≤0.2%
 Rotation.....Counterclockwise (viewed from the flywheel end)
 Minimum no-load speed... .. (600~650) r/min
 Speed control performance level.... ..ISO 8528 G3
 Total dry weight
 Engine... ..11400kg
 Water tank radiator2600kg
 The final weight and size of the engine may vary from specific configuration.

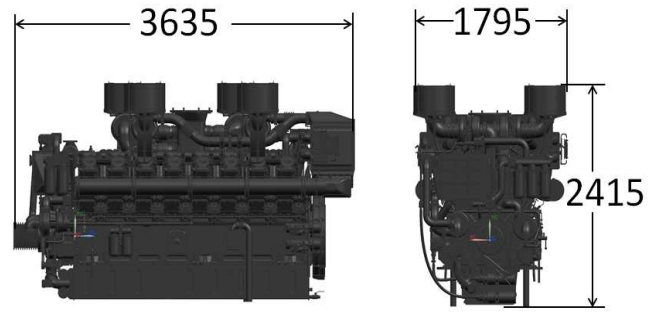

Engine Arrangement

➤ Air Intake System

Air filter
 Turbocharger

➤ Cooling system

Intercooler
 Oil cooler
 Radiator (optional)

➤ Electrical device

24 V electric system

➤ Fuel system

Electronic unit pump
 Fuel Filter
 Mechanical oil delivery pump

➤ Lubrication system

Engine oil filter

➤ Flywheel and flywheel housing

SAE 21" flywheel
 SAE 00# flywheel housing

➤ Documents

Operation Instruction
 Installation Guide
 Parts catalog

Fuel grade: Summer: 0# and 10# ordinary diesel oil of GB 252 - 2015 premium grade or first grade; Winter: 0#, -10#, -20# and -35# ordinary diesel oil of GB 252 - 2015 premium grade or first grade.
 Oil brand: 15W-40 in summer; 10W-30 or other environmentally suitable diesel engine oils with the quality grade not lower than Grade CH-4 as provided in GB 11122-2006 in winter.